

M-400

Translation Stages with Crossed Roller Bearings

Ordering Information

M-405.CG
Translation Stage, 50 mm,
DC Motor/Gearhead

M-410.CG
Translation Stage, 100 mm,
DC Motor/Gearhead

M-415.CG
Translation Stage, 150 mm,
DC Motor/Gearhead

M-405.DG
Translation Stage, 50 mm,
DC Motor/Gearhead

M-410.DG
Translation Stage, 100 mm,
DC Motor/Gearhead

M-415.DG
Translation Stage, 150 mm,
DC Motor/Gearhead

M-405.PD*
Translation Stage, 50 mm,
ActiveDrive™ DC Motor

M-410.PD*
Translation Stage, 100 mm,
ActiveDrive™ DC Motor

M-415.PD*
Translation Stage, 150 mm,
ActiveDrive™ DC Motor

M-405.2S
Translation Stage, 50 mm,
2-phase Stepper Motor

M-410.2S
Translation Stage, 100 mm,
2-phase Stepper Motor

M-415.2S
Translation Stage, 150 mm,
2-phase Stepper Motor

M-405.M0
Translation Stage, 50 mm,
Manual, Leadscrew

M-410.M0
Translation Stage, 100 mm,
Manual, Leadscrew

M-415.M0
Translation Stage, 150 mm,
Manual, Leadscrew

M-592.00 Z-axis Mounting Bracket
for Vertical Mount of M-400 Series
Stages

* Includes 24 V Power Supply for
ActiveDrive™

**Custom Designs
for Volume Buyers**

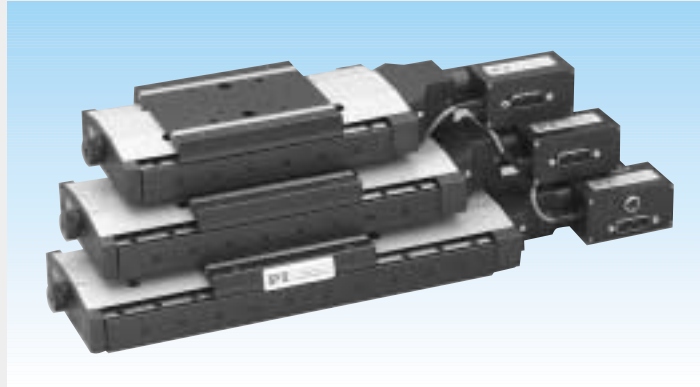

M-405.DG, M-410.DG and M-415.PD translation stages

- **Travel Ranges to 150 mm**
- **Stress-Relieved Aluminum Stage Base for Highest Stability**
- **Crossed Roller Bearings**
- **Manual, DC-Servo and Stepper-Motor Drives, ActiveDrive™ Option**
- **Compatible with Leading Industrial Motion Controllers**
- **Manual Knob for Convenient Position Adjustment**
- **Non-Contact Direction-Sensing Origin Switch**
- **Non-Contact Limit Switches**

M-400 series translation stages are compact, lead-screw-driven stages with a travel range of 50, 100 and 150 mm. Precision crossed roller bearings guarantee 2 µm/100 mm straightness of travel. The stage base is precision machined from high-density, stress-relieved aluminum for exceptional stability and minimum weight.

All models are equipped with low-friction leadscrews for excellent resolution and repeatability. Four motorized versions are available: Models

M-4xx.CG and M-4xx.DG utilize closed-loop DC motors with shaft-mounted position encoders and precision gearheads providing 0.1 µm minimum incremental motion.

ActiveDrive™
Models M-4xx.PD are equipped with the unsurpassed high-resolution ActiveDrive™. This unique design features a high-

efficiency PWM servo-amplifier mounted side-by-side with the DC motor. The ActiveDrive™ provides superior dynamic performance and several other advantages:

- Increased efficiency, by eliminating power losses between the amplifier and motor
- Reduced cost of ownership and improved reliability, because no external driver is required
- Elimination of PWM amplifier noise radiation, by mounting the amplifier and motor together in a single electrically shielded case

Models M-4xx.2S are equipped with direct-drive, 2-phase stepper motors providing 0.1 µm minimum incremental motion with the C-600 controller.

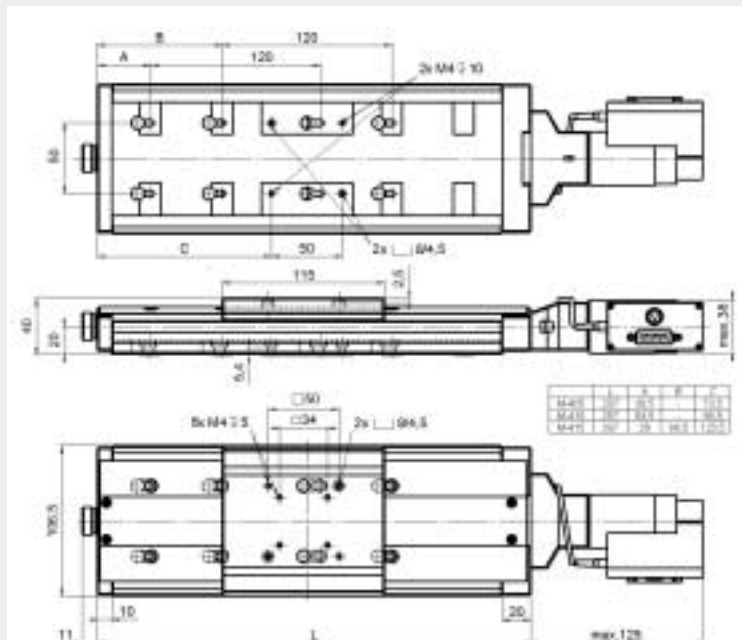

M-405.DG, M-410.DG, M-415.DG, M-405.PD, M-410.PD and M-415.PD dimensions (in mm)

PZT Actuators
PZT Flexure NanoPositioners
PZT Active Optics / Steering Mirrors
Tutorial: Piezoelectrics...
Capacitive Position Sensors
PZT Control Electronics
MicroPositioners / Hexapod Systems
Photonics Alignment & Packaging Systems
Motor Controllers
Index

<http://www.pi.ws>
info@pi.ws

Notes

See "Accessories," page 7-82 ff. for adapters, brackets, etc.

Non-Contact Limit and Origin Switches

Integrated, non-contact, Hall-effect origin and limit switches, with direction sensing on the origin switch, protect your equipment and increase versatility in automation applications (motorized versions only).

M-400 series stages can be cross stacked and combined with the M-592.00 Z-axis mounting bracket to provide multi-axis motion.

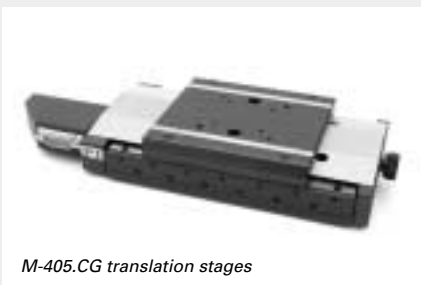
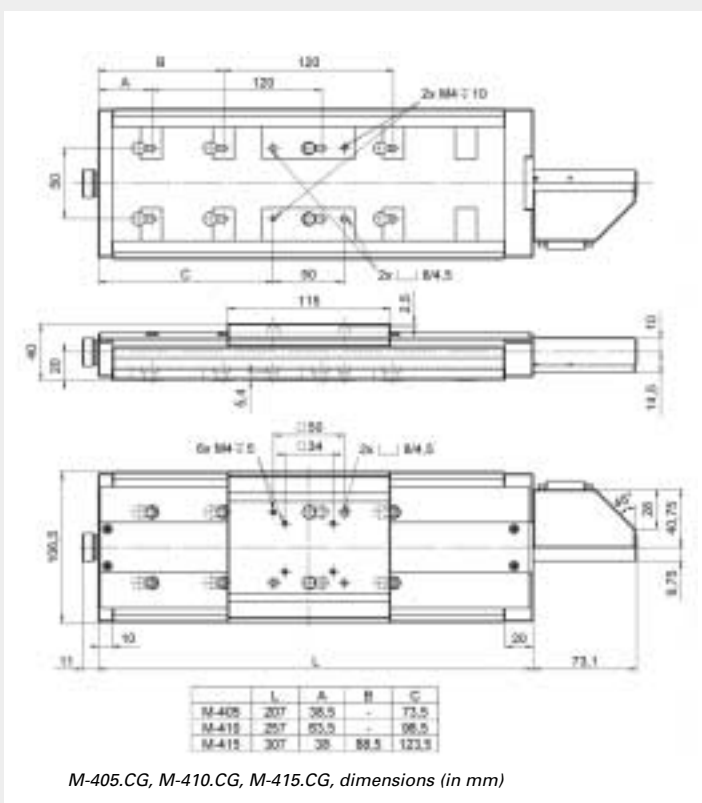

Technical Data

Models	M-405.CG	M-410.CG	M-415.CG	M-405.DG	M-410.DG	M-415.DG	M-405.PD	M-410.PD	M-415.PD	M-405.2S	M-410.2S	M-415.2S	Units	Notes see p. 7-96
Travel range	50	100	150	50	100	150	50	100	150	50	100	150	mm	
Design resolution	0.0035	0.0035	0.0035	0.0085	0.0085	0.0085	0.125	0.125	0.125	0.025	0.025	0.025	µm	A3
Min. incremental motion	0.1	0.1	0.1	0.1	0.1	0.1	0.25	0.25	0.25	0.1	0.1	0.1	µm	A4
Unidirectional repeatability	0.2	0.2	0.2	0.2	0.2	0.2	0.2	0.2	0.2	0.2	0.2	0.2	µm	
Bidirectional repeatability	2	2	2	2	2	2	2	2	2	2	2	2	µm	
Origin repeatability	1	1	1	1	1	1	1	1	1	1	1	1	µm	
Flatness	2	2	3	2	2	3	2	2	3	2	2	3	µm	
Pitch (θ _y)	50	125	150	50	125	150	50	125	150	50	125	150	µrad	
Yaw (θ _x)	50	125	150	50	125	150	50	125	150	50	125	150	µrad	
Max. velocity	1	1	1	1.5	1.5	1.5	15*	15*	15*	6	6	6	mm/sec	
Max. normal load capacity	20	20	20	20	20	20	20	20	20	20	20	20	kg	B1
Max. push/pull force	40 / 40	40 / 40	40 / 40	50 / 50	50 / 50	50 / 50	50 / 50	50 / 50	50 / 50	50 / 50	50 / 50	50 / 50	N	B2
Max. lateral force	150	150	150	150	150	150	150	150	150	150	150	150	N	
Encoder resolution	2048	2048	2048	2000	2000	2000	4000	4000	4000				counts/rev.	
Motor resolution	-	-	-	-	-	-	-	-	-	20000**	20000**	20000**	steps/rev.	
Lead screw pitch	0.5	0.5	0.5	0.5	0.5	0.5	0.5	0.5	0.5	0.5	0.5	0.5	mm/rev.	
Gear ratio	69.12:1	69.12:1	69.12:1	(28/12) ⁴ :1 ≈29.6:1	(28/12) ⁴ :1 ≈29.6:1	(28/12) ⁴ :1 ≈29.6:1	-	-	-	-	-	-		
Nominal motor power	2	2	2	3	3	3	30 ***	30 ***	30 ***	..**	..**	..**	W	
Motor voltage range	0 to ±12	0 to ±12	0 to ±12	0 to ±12	0 to ±12	0 to ±12	0 to ±24	0 to ±24	0 to ±24	24 **	24 **	24 **	V	
Weight	2.0	2.3	2.7	2.1	2.4	2.8	2.1	2.4	2.8	2.1	2.4	2.8	kg	
Length L, A	207, 38.5	257, 63.5	307, 88.5	207, 38.5	257, 63.5	307, 88.5	207, 38.5	257, 63.5	307, 88.5	207, 38.5	257, 63.5	307, 88.5		
Body material	Al, St	Al, St	Al, St	Al, St	Al, St	Al, St	Al, St	Al, St	Al, St	Al, St	Al, St	Al, St	Al, St	L
Recommended motor controller	C-842, C-844, C-860	C-842, C-844, C-860	C-842, C-844, C-860	C-842, C-844, C-860	C-842, C-844, C-860	C-842, C-844, C-860	C-842, C-844, C-860	C-842, C-844, C-860	C-842, C-844, C-860	C-600, C-630	C-600, C-630	C-600, C-630	D2	

* max. recommended velocity, ** 2-phase stepper, 24 V chopper voltage, max. 1.5 A / phase, 20,000 microsteps with C-600, C-630 controllers; *** ActiveDrive™ (integrated PWM servo amplifier)