

**P-840**  
**P-841**

## Preloaded Open- & Closed-Loop LVPZT Translators

### Application Examples

- Static and dynamic positioning
- Disk drive testing
- Smart structures
- Adaptive mechanics
- Vibration cancellation
- Switching
- Laser tuning
- Patch clamping

For more examples see page 1-3

### Ordering Information

#### P-841 Preloaded Closed-Loop LVPZT Translators

##### P-841.10

15  $\mu\text{m}$

##### P-841.20

30  $\mu\text{m}$

##### P-841.30

45  $\mu\text{m}$

##### P-841.40

60  $\mu\text{m}$

##### P-841.60

90  $\mu\text{m}$

#### P-840 Preloaded Open-Loop LVPZT Translators

##### P-840.10

15  $\mu\text{m}$

##### P-840.20

30  $\mu\text{m}$

##### P-840.30

45  $\mu\text{m}$

##### P-840.40

60  $\mu\text{m}$

##### P-840.60

90  $\mu\text{m}$

**Custom Designs for Volume Buyers**



P-840, P-841 PZTs (DIP switch for size comparison)

- Displacement to 90  $\mu\text{m}$
- Pushing Forces to 1000 N
- Pulling Forces to 50 N
- Sub-msec Response
- Sub-nm Resolution
- Options: Ball Tip, Vacuum

P-840 and P-841 preloaded PZT translators are high-resolution linear actuators for static and dynamic applications. They provide sub-millisecond response and sub-nanometer resolution. The internal spring preload makes them ideal for dynamic applications.

The P-840 is specifically designed for open-loop operation. For highest accuracy, the P-841 closed-loop version includes integrated ultra-high-resolution strain gauge position sensors and operate with PI servo-control electronics

(see "Tutorial: Piezoelectrics in Positioning" section, pages 4-21, 4-34 for details).

These translators are equipped with highly reliable multilayer PZT ceramic stacks protected by a non-magnetic stainless steel case with internal spring preload. The standard translator tip and base have tapped holes. Select the P-840.95 ball tip option to help decouple off-axis or torque loads from the translator.

For push/pull forces up to 5 N, the translator can be mounted by clamping around the case. For larger forces, the translator must be mounted by the base. For positioning of magnetic parts the P-176.20 Magnetic Adapter can be screwed into the translator tip.

### Technical Data

Models	Closed-Loop	
	P-841.10	P-841.20
Open-loop travel @ 0 to 100 V	15	30
Closed-loop travel $\geq$	15	30
* Integrated feedback sensor	SGS	SGS
Closed-loop / open-loop ** resolution <	0.3 / 0.15	0.6 / 0.3
**Static large-signal stiffness*	57	27
Push/pull force capacity	1000 / 50	1000 / 50
Torque limit (at tip)	0.35	0.35
Electrical capacitance	1.8	3.6
Dynamic operating current coefficient (DOCC)	15	15
Unloaded resonant frequency ( $f_0$ )	18	14
Standard operating temperature range	-20 to +80	-20 to +80
Voltage connection	VL	VL
Sensor connection	L	L
Weight without cables	20	28
Material case / end pieces	N-S	N-S
Length L	32	50
Recommended Amplifier/Controller (codes explained p. 6-46)	C, D, G, H	C, D, G, H

\* Closed-loop models are supplied with calibration data sheets;  
\*\* Resolution of PZT actuators is not limited by friction or stiction.  
Noise equivalent motion with E-503 amplifier;  
\*\*\* Dynamic small-signal stiffness ~30% higher

**Factory Installed Options**

**P-703.20**  
 High-Vacuum Option  
 (see page 1-40)

**P-840.95**  
 Ball Tip  
 (see page 1-40)

**Accessories**

**P-176.20**  
 Magnetic Adapter with M3  
 Threaded Stud, see page 1-40

Extension cables & connectors: see page 6-43 in the “PZT Control Electronics” section.

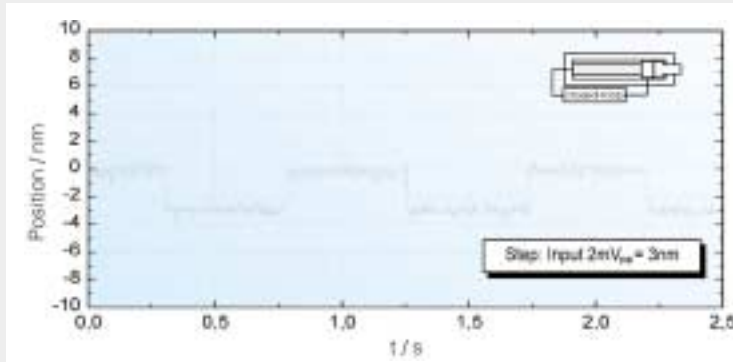

Response of a P-841.10 to a 3 nm peak-to-peak square wave control input signal, measured with servo-control bandwidth set to 240 Hz and 2 msec settling time. Note the crisp response to the square wave control signal.

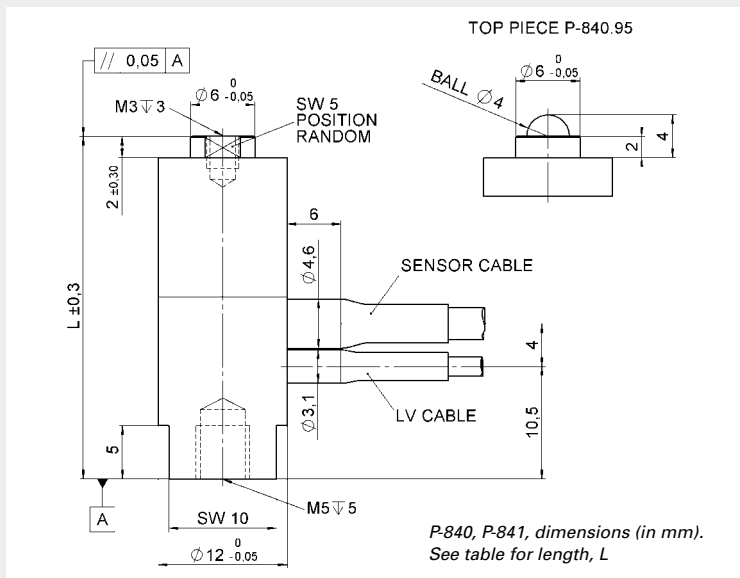

P-840, P-841, dimensions (in mm). See table for length, L

**Notes**

See the “PZT Control Electronics” section for our comprehensive line of low-noise modular and OEM control electronics for computer and manual control. For mounting guidelines see page 1-7.

			Open-Loop					Units	Notes see p. 1-41
P-841.30	P-841.40	P-841.60	P-840.10	P-840.20	P-840.30	P-840.40	P-840.60		
45	60	90	15	30	45	60	90	$\mu\text{m} \pm 20\%$	A2
45	60	90	-	-	-	-	-	$\mu\text{m}$	A5
SGS	SGS	SGS	-	-	-	-	-		B
0.9 / 0.45	1.2 / 0.6	1.8 / 0.9	- / 0.15	- / 0.3	- / 0.45	- / 0.6	- / 0.9	nm	C3
19	15	10	57	27	19	15	10	$\text{N}/\mu\text{m} \pm 20\%$	D1
1000 / 50	1000 / 50	1000 / 50	1000 / 50	1000 / 50	1000 / 50	1000 / 50	1000 / 50	N	D3
0.35	0.35	0.35	0.35	0.35	0.35	0.35	0.35	Nm	D6
5.4	7.2	10.8	1.8	3.6	5.4	7.2	10.8	$\mu\text{F} \pm 20\%$	F1
15	15	15	15	15	15	15	15	$\mu\text{A}/(\text{Hz} \times \mu\text{m})$	F2
10	8.5	6	18	14	10	8.5	6	$\text{kHz} \pm 20\%$	G2
-20 to +80	-20 to +80	-20 to +80	-20 to +80	-20 to +80	-20 to +80	-20 to +80	-20 to +80	$^{\circ}\text{C}$	H2
VL	VL	VL	VL	VL	VL	VL	VL		J1
L	L	L	-	-	-	-	-		J2
46	54	62	20	28	46	54	62	$\text{g} \pm 5\%$	K
N-S	N-S	N-S	N-S	N-S	N-S	N-S	N-S		L
68	86	122	32	50	68	86	122	$\text{mm} \pm 0.3$	
C, D, G, H	C, D, G, H	C, D, G, H	C, G	C, G	C, G	C, G	C, G		